

**7-Channel DC-DC Converter for DSC****Features**

- 1.5V ~ 5.5V Input Voltage Operation.
- 95% Efficient DC/DC Converter.
- Highly Integrated 7-CH DC/DC with integrated Power MOSFETs.
- Main Channel Selectable Buck or Boost for 2*AA or Li-Ion Application.
- Built-in 6 Channel Synchronous Rectified Current-Mode PWM Converter, 1 Channel Non-Synchronous Rectified Current-Mode PWM Converter.
- Selectable Boost Type with LED open protection or Current Regulation Type LED Driver.
- 32-steps brightness control for LED Driver
- Built-in HV LDO and RTC LDO
- Low Power Consumption (Sleep Mode) < 10 μ A.
- Built-In Power ON/OFF Sequence for 4 Channel Synchronous Rectified Converter.
- Built-In Power ON Sequence for CCD+, CCD-power.
- Built-In Short Circuit Protection (SCP) & Under Voltage Protection (UVP) .
- Cycle-by-Cycle current limit for DC/DC Converter
- Built-In Thermal Shutdown Function.
- Built-In Battery OVP Function.
- Built-In Soft-Start Function.
- Built-In True Shutdown in Boost Converter.
- Fixed 1.5MHz / 750KHz Operating Frequency.
- TQFN4x4-32 Package.

General Description

The G2202/G2202B provide a complete power supply solution for digital cameras. They improve performance, component count, and size compared to other multi-channel controllers in 2-cell AA, 1-cell Li-Ion, and multi-battery designs. On-chip MOSFETs provide up to 92~95% efficiency for critical power supplies. Except for CCDBST and LED Driver, All channels DC/DC operate at one fixed frequency of 1.5MHz to optimize size, cost, and efficiency. They also feature True-Shutdown as well as internal compensation to minimize external component count.

Applications

- DSC Power Supply

Ordering Information

ORDER NUMBER	MARKING	TEMP. RANGE	PACKAGE (Green)
G2202K11U	2202	-20°C to +85°C	TQFN4X4-32
G2202BK11U	2202B	-20°C to +85°C	TQFN4X4-32

G2202: CH1-CH2-CH4-CH3, G2202B:CH1-CH4-CH3-CH2

Note: K1: TQFN4X4-32

1: Bonding Code

U: Tape & Reel

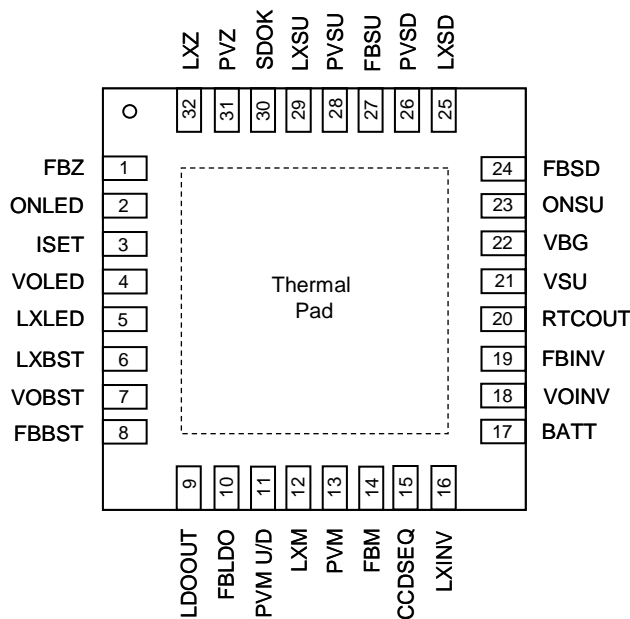
Pin Configurations

G2202/G2202B TQFN4X4-32

Note: Recommend connecting the Thermal Pad to the Ground for excellent power dissipation.

